

Tuning the Ionization Energy of Organic Semiconductor Films: The Role of Intramolecular Polar Bonds

Ingo Salzmann, Steffen Duhm, Georg Heimel, Martin Oehzelt, Rolf Kniprath, Robert L. Johnson, Ju#rgen P. Rabe, and Norbert Koch

J. Am. Chem. Soc., **2008**, 130 (39), 12870-12871 • DOI: 10.1021/ja804793a • Publication Date (Web): 05 September 2008

Downloaded from <http://pubs.acs.org> on February 8, 2009

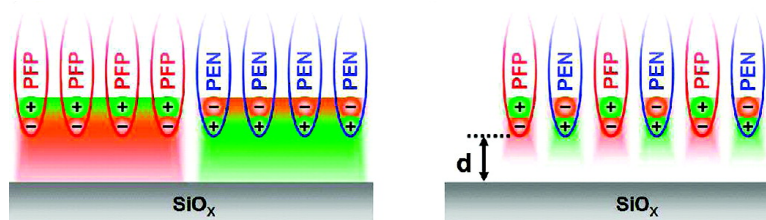

More About This Article

Additional resources and features associated with this article are available within the HTML version:

- Supporting Information
- Access to high resolution figures
- Links to articles and content related to this article
- Copyright permission to reproduce figures and/or text from this article

[View the Full Text HTML](#)

Tuning the Ionization Energy of Organic Semiconductor Films: The Role of Intramolecular Polar Bonds

Ingo Salzmann,[†] Steffen Duhm,[†] Georg Heimel,[†] Martin Oehzelt,[‡] Rolf Kniprath,[†]
Robert L. Johnson,[§] Jürgen P. Rabe,[†] and Norbert Koch^{*†}

Institut für Physik, Humboldt-Universität zu Berlin, Newtonstrasse 15, D-12489 Berlin, Germany, Institut für Experimentalphysik, Johannes Kepler Universität Linz, Altenbergerstrasse 69, A-4040 Linz, Austria, and Institut für Experimentalphysik, Universität Hamburg, Luruper Chaussee 149, D-22761 Hamburg, Germany

Received June 28, 2008; E-mail: norbert.koch@physik.hu-berlin.de

The mechanisms that govern surface and interface energetics of metals and conventional inorganic semiconductors have been studied for decades. In contrast, fairly little is known about the impact of surface termination on the electronic structure of organic semiconductor surfaces and the energy level alignment at organic/(in)organic heterojunctions. Recently, it was shown that an inhomogeneous charge-distribution within individual π -conjugated molecules impacts the ionization energy (IE) of and the charge injection barriers into organic thin films.¹ It was suggested that polar end-group substitution of a molecule should permit predictably adjusting the IE of ordered layers. Moreover, the proposed model also predicts that the IE of mixed ordered molecular layers, comprising two molecular species with different polar end-groups, should assume a value in between those of layers comprising only one compound.

In the present Communication, we experimentally demonstrate both (1) IE tuning via molecular orientation and intramolecular polar bonds and (2) IE tuning by appropriate mixing of two molecular species. For that purpose, we use the prototypical organic semiconductors pentacene (PEN) and perfluoropentacene (PFP), which exhibit high charge carrier mobilities in organic field-effect transistors (OFETs) of up to $5.5 \text{ cm}^2/\text{V}\cdot\text{s}$ for holes (PEN)² and $0.2 \text{ cm}^2/\text{V}\cdot\text{s}$ for electrons (PFP).³ In thin films, both molecules have an almost upright standing orientation on SiO_x substrates,^{4–9} a common gate dielectric in OFETs. In such PFP films the surface is terminated by strongly polar bonds; the strongly electronegative fluorine carries a negative partial charge [δ^-] compared to the backbone carbon atoms [δ^+] leading to a surface dipole moment (μ) pointing toward the molecular cores. In PEN, only a small positive partial charge [δ^+] on the hydrogen atoms compared to the conjugated backbone [δ^-] exists. The latter thus leads to a (small) surface dipole pointing in the opposite direction compared to PFP.¹⁶ The existence of a (molecular orientation dependent) surface dipole layer affects the IE,¹ since it causes a jump in the electrostatic potential energy, hence shifting the vacuum level (E_{VAC}).^{10–12}

(1) Our ultraviolet photoelectron spectroscopy (UPS) results for PEN and PFP films (Figure 1) of nominally 3.2 nm thickness on SiO_x substrates (ca. 2 layers of *standing* molecules) demonstrate the effect of layer termination in organic solids by polar intramolecular bonds on their IE (see Figure 2a). Values of *lying* molecular layers of PEN and PFP on $\text{Au}(111)$ ¹³ are indicated for comparison in Figure 1. Clearly, we observe highly orientation dependent IEs for both molecules; however, with opposite trends between standing and lying orientation: For PEN, the IE of the standing molecules

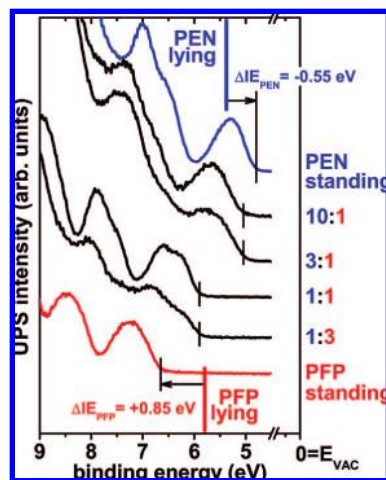

Figure 1. UPS spectra of pure and mixed films of standing PEN and PFP on SiO_x . The vertical lines indicate the photoemission onsets, i.e., the IE (values of lying PEN and PFP on $\text{Au}(111)$ ¹³ are given for comparison).

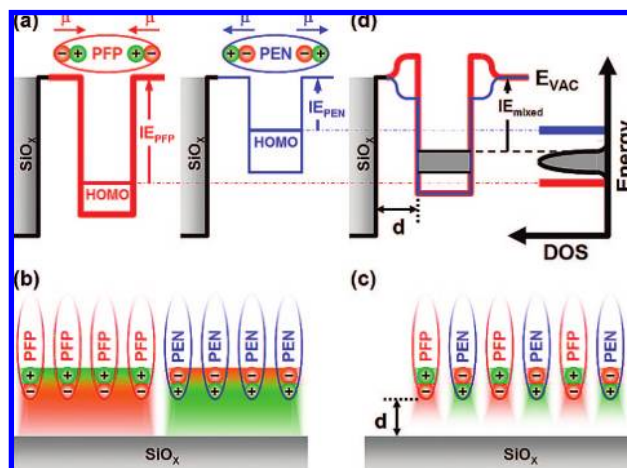

Figure 2. (a) Schematics of the pure film energetics; (b) the electrostatic potential at the organic/ SiO_x interface for the (hypothetical) case of large-scale phase separation, and (c) molecular-level mixing, where orange (green) indicates regions of higher (lower) electron potential energy; the white area between molecules and substrate indicates an intermediate value. (d) Schematic of the mixed film energetics (for details see text).

(4.80 eV) is *lower* than that of lying molecules (5.35 eV),¹³ whereas the layer of standing PFP exhibits a *higher* IE value (6.65 eV) than that of lying molecules (5.80 eV).¹³ The oppositely oriented dipolar surface terminations of PEN and PFP films (due to different intramolecular dipolar bonds exposed at the surface) strongly impact

[†] Humboldt-Universität zu Berlin.

[‡] Johannes Kepler Universität Linz.

[§] Universität Hamburg.

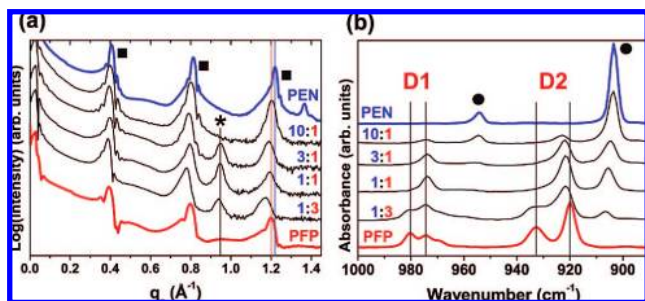

Figure 3. (a) XRD data on films of pure and mixed (10:1, 3:1, 1:1 and 1:3) PEN and PFP; q_z denotes the vertical momentum transfer; squares indicate peaks originating from standing molecules; the star marks a second molecular orientation in the mixed films. (b) FTIR spectra of the respective samples; D1 and D2 denote two Davydov-split peaks of PFP (both C–F/C–C in-plane vibrations), the circles mark C–H out-of-plane vibrations of PEN that are not split.

the IE values in the anticipated way: The difference between the lying/standing IE for PEN layers is $\Delta IE_{\text{PEN}} = -0.55$ eV while for PFP this difference is $\Delta IE_{\text{PFP}} = +0.85$ eV.

(2) The remarkably high IE difference between standing PEN and PFP of 1.85 eV suggests that mixing the two molecules in different ratios should allow a gradual shift of the thin film IE between the values of pure PEN and PFP, thus “dialing” in the overall IE of the organic semiconductor film. To demonstrate this effect, two requirements must be met by the samples: (i) the molecules in mixed films must still adopt a standing orientation and (ii) the mixing of PEN and PFP must occur on the molecular length-scale. Long-range phase separation, that is, adjacent patches of pure PEN and PFP, would lead to *individual* vacuum level alignment of the PEN and PFP patches with the SiO_x substrate, thus simply yielding a superposition of the respective UPS spectra, as schematically shown in Figure 2a,b. Only if the lateral distance between the two different molecular species is sufficiently small (Figure 2c), that is, in the range of the molecule–substrate adsorption distance (d on the order of 1 nm), a common electrostatic potential is established on the length scale of d . This is then aligned with the surface potential of the SiO_x substrate.¹⁴ Only in this case an overall IE_{mixed} between the extreme cases of the pure films can be observed (Figure 2c,d; for details see Supporting Information).

We realized crystalline mixed (on a molecular length-scale) PEN and PFP thin films via vacuum codeposition of PEN and PFP on SiO_x . For the investigated mixing ratios, specular X-ray diffraction (XRD) results (Figure 3a) show a peak series corresponding to *standing* molecules with an increased lattice spacing compared to the pure PEN and PFP thin film phases.^{3–9} In addition, XRD provides evidence for the presence of a differently oriented (almost lying) mixed film phase with a lattice spacing independent of the mixing ratio (denoted with a star in Figure 3a). This phase is attributed to a 1:1 phase of PEN and PFP. However, atomic force microscopy (AFM) investigations (see Supporting Information) revealed that the surface area covered by this almost lying phase is less than 15%, thus contributing very little to the UPS spectra (which are acquired area-averaged over ca. 1 mm²). Fourier-transform infrared spectroscopy (FTIR) proves the intercalation of PEN and PFP on the molecular scale, because the Davydov-splitting of lines D1 and D2 found in pure PFP films (D1 and D2 in Figure 3b) is removed in mixed films. (The Davydov-splitting is caused by the presence of two translationally inequivalent molecules of

the same species per unit cell;¹⁷ see Supporting Information for further details). In addition, preliminary studies show that also the optical absorption spectra of mixed PEN:PFP films are not simple superpositions of spectra of individual materials.¹⁵

These mixed PEN:PFP thin films could thus be used to experimentally confirm prediction 2: a gradual change of the IE depending on the mixing ratio was observed (Figure 1). While the IE is a macroscopic material property, the internal electronic structure of the mixed organic semiconductor bulk is not directly accessible (Figure 2d). Deviations from a strict linear dependence of the IE on the PEN:PFP mixing ratio and comparably large error bars (see Figure S3 in the Supporting Information) are attributed to deviations from a uniform mixing ratio across the sample, which is particularly important for samples with PFP majority.

In conclusion, we have shown that the surface termination of ordered organic thin films with intramolecular polar bonds can be used to tune their IE. The collective electrostatics of these oriented bonds also explains the pronounced orientation dependence of the IE. Furthermore, mixing of differently terminated molecules on a molecular length scale allows continuously tuning the IE of thin organic films between the limiting values of the two pure materials. Our study shows that surface engineering of organic semiconductors via adjusting the polarity of intramolecular bonds represents a viable alternative to the surface modification of substrates to control the energetics at organic/(in)organic interfaces.

Acknowledgment. We thank Y. Sakamoto and T. Suzuki (Institute for Molecular Science, Myodaiji, Japan) for providing PFP and W. Caliebe (HASYLAB, Hamburg, Germany) for experimental support. This work was supported by the Sfb448 (DFG). G.H. acknowledges financial support by the Marie-Curie OIF project 021511, R.K. by H. C. Starck GmbH, and N.K. by the Emmy-Noether-Program (DFG).

Supporting Information Available: Experimental details, electrostatic modeling, and AFM micrographs. This material is available free of charge via the Internet at <http://pubs.acs.org>.

References

- (1) Duhm, S.; Heimel, G.; Salzmann, I.; Glowatzki, H.; Johnson, R. L.; Vollmer, A.; Rabe, J. P.; Koch, N. *Nat. Mater.* **2008**, *7*, 326.
- (2) Singh, T. B.; Senkarabacak, P.; Sariciftci, N. S.; Tanda, A.; Lackner, C.; Hagelauer, R.; Horowitz, G. *Appl. Phys. Lett.* **2006**, *89*, 033512.
- (3) Inoue, Y.; Sakamoto, Y.; Suzuki, T.; Kobayashi, M.; Gao, Y.; Tokito, S. *Jpn. J. Appl. Phys.* **2005**, *44*, 3663.
- (4) Nabok, D.; Puschig, P.; Ambrosch-Draxl, C.; Werzer, O.; Resel, R.; Smilgies, D. M. *Phys. Rev. B* **2007**, *76*, 235322.
- (5) Schiefer, S.; Huth, M.; Dobrineski, A.; Nickel, B. *J. Am. Chem. Soc.* **2007**, *129*, 10316.
- (6) Yoshida, H.; Inaba, K.; Sato, N. *Appl. Phys. Lett.* **2007**, *90*, 181930.
- (7) Sakamoto, Y.; Suzuki, T.; Kobayashi, M.; Gao, Y.; Fukai, Y.; Inoue, Y.; Sato, F.; Tokito, S. *J. Am. Chem. Soc.* **2004**, *126*, 8138.
- (8) Kowarik, S.; Gerlach, A.; Hinderhofer, A.; Milita, S.; Borgatti, F.; Zontone, F.; Suzuki, T.; Biscarini, F.; Schreiber, F. *Phys. Stat. Sol.* **2008**, *2*, 120.
- (9) Salzmann, I.; Duhm, S.; Heimel, G.; Rabe, J. P.; Koch, N.; Oehzelt, M.; Sakamoto, Y.; Suzuki, T. *Langmuir* **2008**, *24*, 7294.
- (10) Cahen, D.; Kahn, A. *Adv. Mater.* **2003**, *15*, 271.
- (11) Ishii, H.; Sugiyama, K.; Ito, E.; Seki, K. *Adv. Mater.* **1999**, *11*, 605.
- (12) Natan, A.; Kronik, L.; Haick, H.; Tung, R. *Adv. Mater.* **2007**, *19*, 4103.
- (13) Koch, N.; Vollmer, A.; Duhm, S.; Sakamoto, Y.; Suzuki, T. *Adv. Mater.* **2007**, *19*, 112.
- (14) Koller, G.; Winter, B.; Oehzelt, M.; Ivanco, J.; Netzer, F.; Ramsey, M. *Org. Electron.* **2007**, *8*, 63.
- (15) Hinderhofer, A.; Heinemeyer, U.; Gerlach, A.; Kowarik, S.; Jacobs, R. M. J.; Sakamoto, Y.; Suzuki, T.; Schreiber, F. *J. Chem. Phys.* **2007**, *127*, 194705.
- (16) Note: both molecules do not exhibit any external net dipole moment.
- (17) The mixed film with PFP majority (1:3) seems to contain a certain portion of pure crystalline PFP, as evidenced by the remaining Davydov-components at higher wavenumbers in Figure 3b.

JA804793A